

TransLogic® 6-Inch 230 and 460 VAC Blower Unit Specification

The blower unit provides vacuum and pressure to move carriers at consistent speeds regardless of payload or proximity to the blower. The unit consists of a heavy-duty regenerative blower motor rated for continuous duty and a shifter valve mechanism used to connect either vacuum or pressure to the system piping as required. Blowers can be equipped with an optional variable frequency drive (VFD).

VFD-equipped models provide software control of the blower speed enabling transport of sensitive items at slower speeds and empty carriers at faster speeds.

The blower unit is an open-frame design and is suitable for installation in areas such as mechanical equipment rooms.

6-Inch 230 and 460 VAC Blower Specification

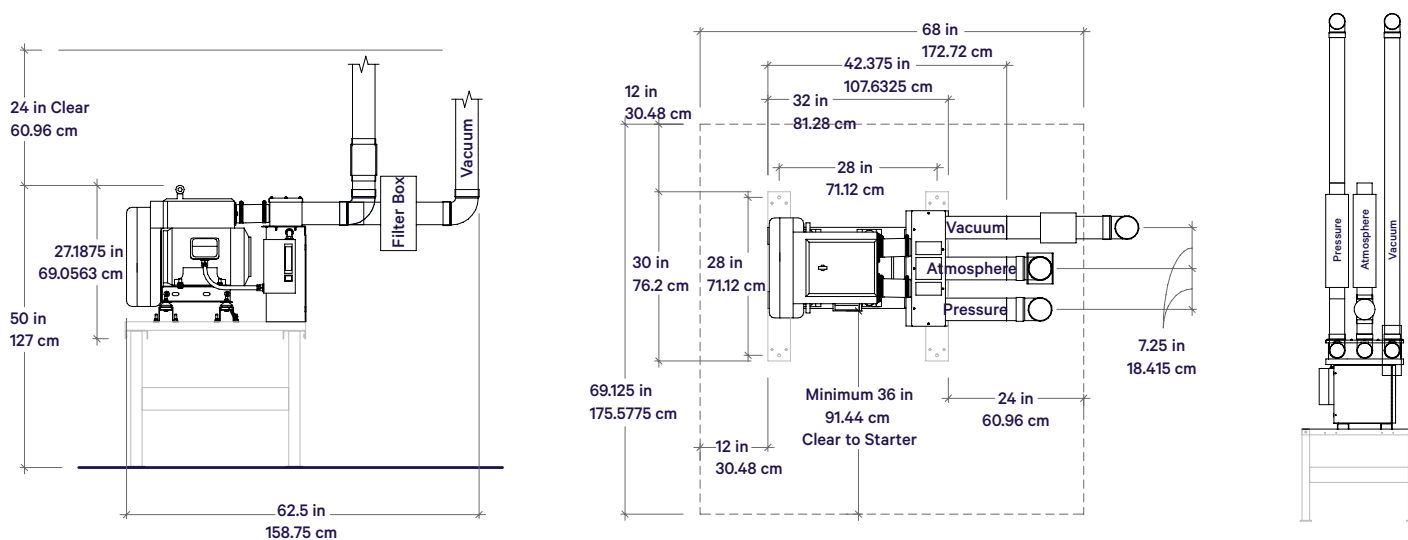

Blower Type: Regenerative

Power Requirements:

Shifter Valve Motor: 105-125 VAC, 50/60 Hz, 1 Phase

Blower Motor: 230 and 460 VAC, 50/60 Hz, 3 Phase

| | Horsepower* | Full Load Amperage* | Pressure-Side Airflow |
|---------|-------------|---------------------|-----------------------|
| 230 VAC | 10 | 22.6 | 370 SCFM |
| 460 VAC | 10 | 11.5 | 370 SCFM |

*Size all circuit protection in accordance with local, state, and national electrical codes.

Weight:

Open frame 310 lbs/141 kg max

Open frame (w/VFD) 320 lbs/145 kg max

Environmental Requirements:

Operating Temperature 30° to 120° F (-1° to 49° C)

Storage Temperature -20° to 180° F

(29° to 82° C)

Relative Humidity 0 to 90%

Local Heat output: (approximately) 9000 BTU/hr

Sound Levels:

In open area (open frame) 82 dbA

In open area (attenuated) 72 dbA

Mounted above ceiling 61-66 dbA

Control Requirements:

LAN/Ethernet (preferred): 100 Base-T, Category 5e cable or better

Serial (alternate): 4-conductor cable, #22 AWG stranded, 5 VDC maximum open-circuit voltage, 200 mA maximum short-circuit current



Available Options

- Variable Frequency Drive
- Sound Attenuation
(available as factory-installed option only)



Sound Attenuated Model

An optional sound attenuated model completely enclosed in a sheet metal housing with sound absorbing lining and equipped with mufflers is also available. The sound attenuated version permits installation near occupied areas. Both models use blower motor isolation mounts, insulating vibrations from the structure. To conserve energy, the blower is automatically turned off during periods of inactivity.

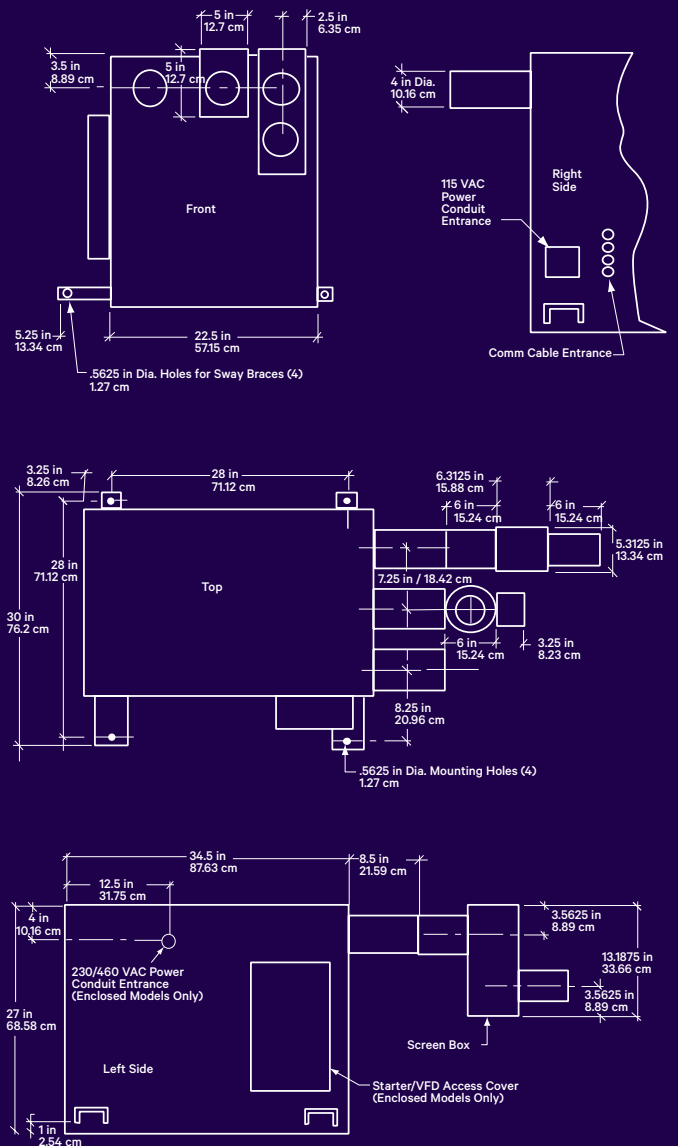

About Us

Swisslog Healthcare is the leading supplier of automation solutions and workflow consulting for material transport, medication management and warehouse distribution in healthcare facilities. Swisslog Healthcare has installed facility-wide automated material transport and pharmacy automation systems in more than 3,000 hospitals worldwide, including more than 2,200 in North America.

Denver-based Swisslog Healthcare offers material transport consulting, total system design, manufacturing, installation and customer support—providing comprehensive solutions for lean workflow and operations that enhance information access, patient safety and cost efficiency.



CONTACT

Swisslog Healthcare
healthcare.us@swisslog-healthcare.com
800.764.0300
Canada: 877.294.2831 | 905.629.2400
swisslog-healthcare.com/translogic

Swisslog Healthcare conducts ongoing product improvements, therefore technology designs may change without notice or obligation. TransLogic is a trademark registered in the US Patent and Trademark Office. Swisslog Healthcare systems may be covered by one or more patents. See swisslog-healthcare.com/patents for details. © 2021 Swisslog Healthcare NAM EN 092021 PTS-237, PN 1001039061A

